

# **IQBoard ET & PS**

## **User Manual**



Copyright(C) 2003-2009 Returnstar Technology Co., Ltd.

Web: [www.recoverystar.com](http://www.recoverystar.com); [www.iqboard.net](http://www.iqboard.net)

Tel: +86-591-83385086, 87274373

Fax: +86-591-87274383

E-mail: [master@recoverystar.com](mailto:master@recoverystar.com)

## **Important Statements**

This manual is for IQBoard ET and IQBoard PS.

The “Whiteboard” or “Interactive Whiteboard” in this manual all refer to IQBoard ET or IQBoard PS. The “Electronic Pen” is used for IQBoard ET. The “Colorless Writing Pen (Finger)” is used for IQBoard PS.

Use this product strictly according to detailed operation instruction in this manual so as to ensure proper use. Before you install this product, please read this manual carefully to save your time.

Opening the package means you have agreed to purchase this product, Returnstar will not accept returns of opened packages.

The product specification may be subject to change without prior notice. The sample pictures in this User Manual may differ from the real product.

Returnstar reserves all rights to charge the fee at anytime for product replacement, revision and update. The content in this manual will be regularly revised without prior notice, and the printed manual will be updated when new version is released. Returnstar will make no guarantee for this product, both explicit and implicit, including the salability and the adaptability to certain purpose, and will deny all guarantees alike.

## **Copyright**

Returnstar, IQBoard are registered trademarks of Returnstar Technology Co., Ltd. Window is a registered trademark of Microsoft.

## **Environment Protection**

When discarding this electronic device, please don't treat it as normal trash. To minimize the pollution and protect the environment, please recycle it.

## **Working Temperature and Humidity**

Storage: Temperature: -40 degrees to 60 degrees; Humidity: 0% to 95%

Operation: Temperature: 0 degrees to 40 degrees; Humidity: 15% to 85%

# Chapter 1 Product Introduction

IQBoard ET and IQBoard PS are the latest interactive presentation boards. Connect IQBoard ET or PS with your computer and projector, then simply touch the projection area with electronic pen or your finger, you can transform the electronic pen or your finger to mouse and directly operate the computer on the projection area. The difference between IQBoard ET and PS are IQBoard ET adopts electronic pen for operation, and while IQBoard PS can be directly operated by your finger.

With IQBoard ET or PS, marvelous interactive communicating effect can be achieved in various demonstrating and teaching situation, such as product exhibition, business conference, video communication, news broadcast, securities evaluation, military command, entertainment, medical consultation, engineering design, competition tactics analysis, weather analysis, etc.

IQBoard ET and PS are provided with powerful IQBoard Software, which makes your operation on interactive whiteboard more convenient. Its powerful functions include writing, erasing, text editing, hand-writing recognition, on-screen keyboard, line, graph and table editing, graph recognition, video and sound playing, dimension and angle label, digital teaching tools, slide playing, operation review, dragging, revolving, hyperlink, reveal screen, spotlight, screen capture, screen record and replay, hand-writing saving in MS Office, page and file editing, printing and saving, etc.

IQBoard Software also includes 500M IQBoard Resource Library covering more than 30 subjects, such as math, physics, chemistry, biology, gymnasium, etc. User can customize the installation by selecting subjects. Also provide common line, shape, character, symbol, decoration graph, background template, Flash courseware, and other resources. Support importing various picture files and DOC, PPT, XLS files. The page and file created by IQBoard Software can be save as and freely converted to various picture files as well as DOC, PPT, XLS, PDF, HTML files, etc.

We provide continuous upgrading service for IQBoard Software. For more information and detailed operation about IQBoard Software, please refer to “IQBoard Software V4.3 User Manual” in the installation CD.

## Chapter 2 Specification

**Performance:** Effective resolution: 9600×9600, 300dpi; Signal tracking rate: 3m/s; Processing rate for writing or clicking: 240 dot/s. Provide 9 or 20 points precise orientation. Power consumption for electronic pen: ≤1 W. IQBoard ET provides sizes of 80 inches, 60 inches, 50 inches (4:3), 100 inches, 120 inches (16:9) and customized sizes. IQBoard PS provides sizes of 80 inches, 60 inches (4:3), 100 inches, 112 inches (16:9) and customized sizes.

**Hotkeys:** Provide 28 hotkeys to achieve frequently used functions of IQBoard Software, 14 on each side of whiteboard surface or frame.



**Prompt:** *You can use either the physical hotkeys (hard hotkey) on each side of whiteboard frame, or the virtual hotkeys (soft hotkey) on each side of whiteboard surface. In the latter case, you need to set these hotkeys at the first time you use the interactive whiteboard.*

**Flexible fixing and relocating methods:** Fixing methods include wall hanging, cabinets, and mobile stand. Provide optional height adjustable mobile stand for 50-120 inch whiteboards, the height can be adjust from 1.88M to 2.12M.

**Durable surface, solid body:** The surface adopts dedicated writing film made of DuPont anti-abrasive coating. It features with anti-scratch, high luminance, high definition, easy cleaning (can be cleaned by whiteboard detergent or wet cloth), and can completely eliminate bright spots. The backboard adopts aviation aluminum beehive-board, which is resistant to distortion, expansion and shrinkage (Provide model supporting normal pen writing).

**PC Connection:** Provide 10M USB cable for connecting IQBoard with PC. External power is not required. Provide optional USB signal amplifier for 25M USB cable. Provide optional 2.4G radio frequency wireless module (Effective range: 10M).

**Standard Configuration:** 1 interactive whiteboard, 2 electronic pens (include battery) or 2 colorless writing pen, 1 10M USB cable, 1 wall hanging suit, 1 driver CD (include the latest driver and user manual), 1 IQBoard Software (include user manual).

**About Model**

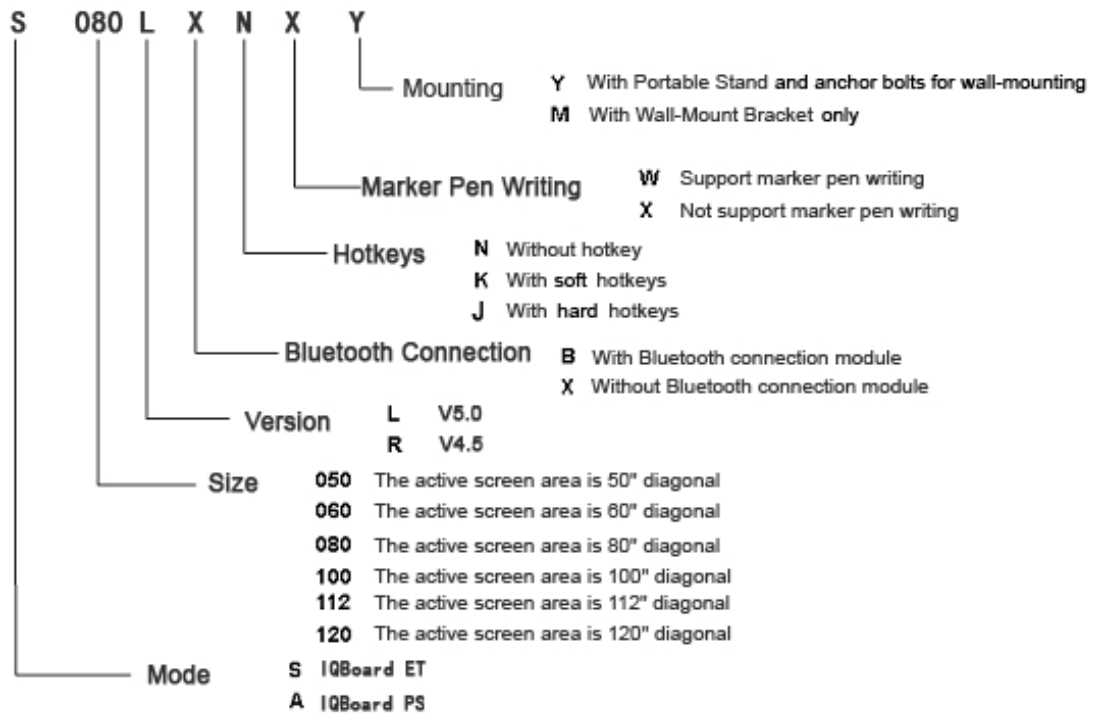

## System Requirement

- Windows XP/2003/Vista operation system
- Pentium166 CPU (PentiumII or higher recommended)
- 64 MB RAM (128 MB recommended)
- 1G free hard disk space (for full installation)
- 1 free USB port
- 1 projector (short focus or ultra-short focus projector recommended)

# Chapter 3 Setup Hardware

## 3.1 Mount Whiteboard

### 3.1.1 For product with an “M” on its name

In case your product having an “M” on its name, you can select wall mounting.

Parts list:

Picture	Name	Quantity
	Screw	4
	Wall Anchor	2
	Safety Bracket	2
	Anchor Bolt	2
	Wall Mounting Bar	1
	Wall Mounting Bracket (already mounted on the backboard)	2

Installation Steps:

Step 1. Determine the installation height of the Wall Mounting Bar (190cm above floor), then fasten bracket to wall using the two Anchor Bolts.

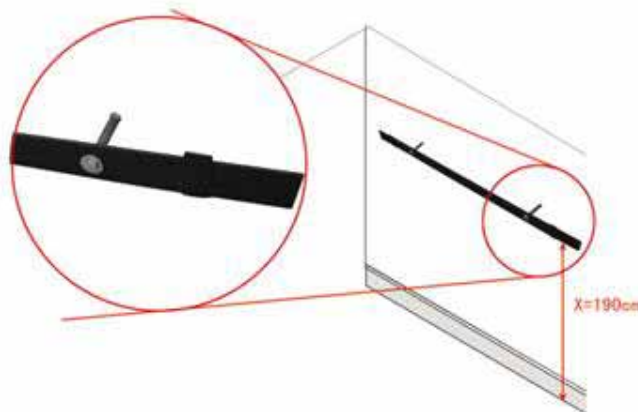



**Note:** When mounting the Wall Mounting Bar, mind its direction.

Step 2. Align the 2 Wall Mounting Brackets on the backboard with the Wall Mounting Bar, and hang the whiteboard on the wall.

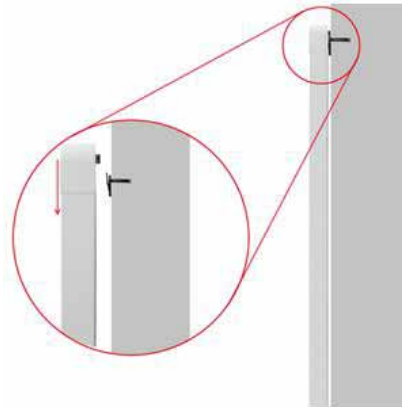

Step 3. Fasten the 2 Safety Brackets on each side of whiteboard lower frame using 2 Screws. According to the location of the Safety Brackets, drill 2 mounting holes on the wall. Finally use Wall Anchors and Screws to fix the Safety Brackets on the wall.

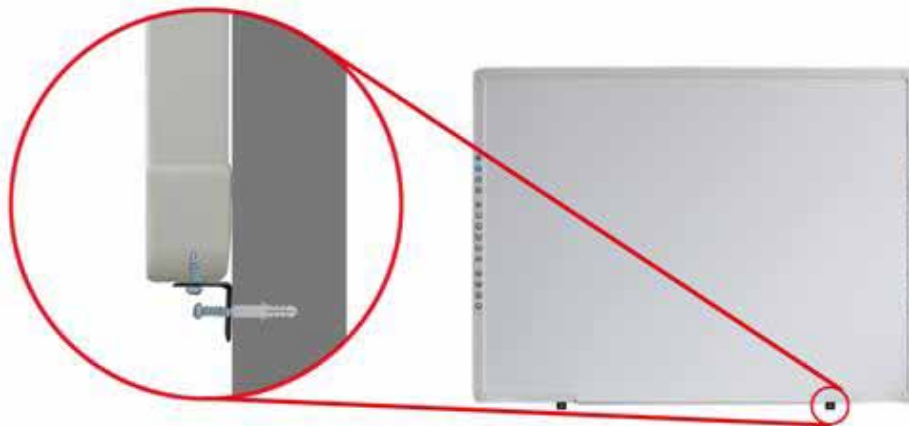





### 3.1.2 For product with a “Y” on its name

In case your product having a “Y” on its name, you can select either wall mounting or stand mounting.

#### Wall Mounting

Part list:

Picture	Name	Quantity
	Screw	4
	Wall Anchor	2
	Safety Bracket	2
	Anchor Bolt	4
	Height Adjust Bracket (already mounted on backboard)	4

#### Installation Steps:

Step 1. Drill 4 holes at the location where you want to place the 4 Anchor Bolts, insert the 4 Anchor Bolts in these holes, and leave 4mm clearance between bolt head and nut for hanging whiteboard.

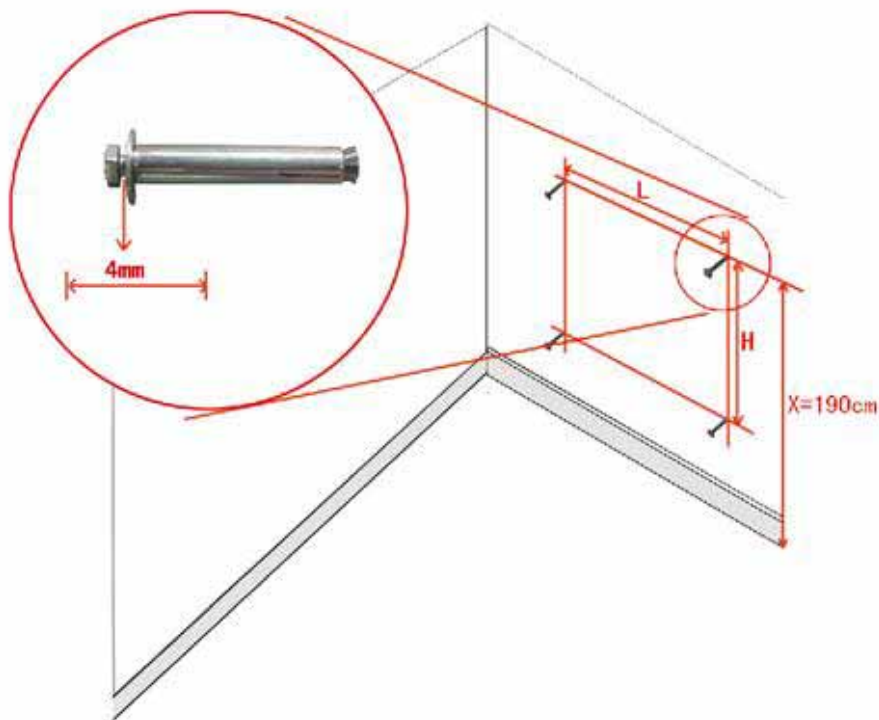



**Prompt:** The distance from floor to the 2 anchor bolts on top (Distance X) is 190cm. The vertical distance between 2 anchor bolts (Distance H) is 45cm for the 50" and 60" whiteboards, and 75cm for the 80", 100", 112", and 120" whiteboards. For the horizontal distance between 2 anchor bolts (Distance L), please measure horizontal distance of the 2 Height Adjust Brackets on the backboard.

Step 2. Align the Anchor Bolts with the clip holes of Height Adjusting Bracket on backboard, and then hang the whiteboard on the wall.

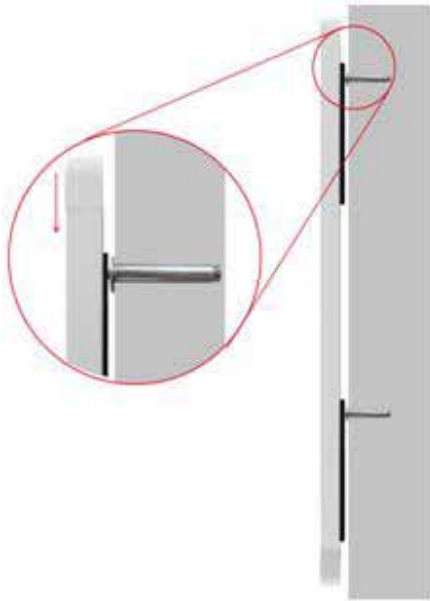



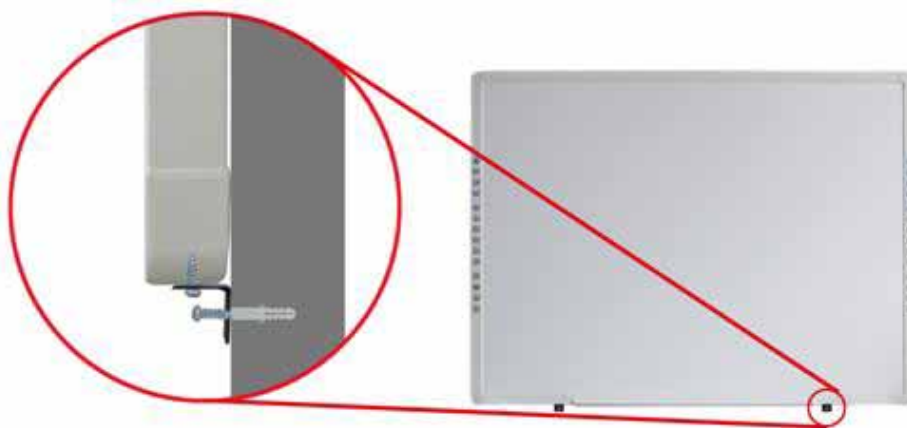





Step 3. Fasten the 2 Safety Brackets on each side of whiteboard lower frame using 2 Screws. According to the location of the Safety Brackets, drill 2 mounting holes on the wall. Finally use Wall Anchors and Screws to fix the Safety Brackets on the wall.



**Stand Mounting**

Parts list:

Picture	Name	Quantity
	Caster (with locking system)	4
	Horse	2
	Column	2
	Stabilizing Foot	2
 <p data-bbox="236 1350 1002 1422">Each assembly includes 1 Hexagon Bolt, 2 Nuts, 1 Small Galvanized Washer, 1 Big Galvanized Washer</p>	Hexagon Bolt Assembly (1)	4
 <p data-bbox="236 1601 1002 1673">Each assembly includes 1 Hexagon Bolt, 2 Nuts, 1 Galvanized Washer</p>	Hexagon Bolt Assembly (2)	6
	Double-end wrench	1
	Height Adjust Bracket (already mounted on backboard)	4

Installation Steps:

Step 1. Install 2 Casters on each Horse.



Step 2. Install Column on each Horse using 2 Hexagon Bolt Assemblies (2).



Step 3. Install Stabilizing Foot on each Horse using Hexagon Bolt Assembly (2).



Step 4. Install 2 Hexagon Bolt Assemblies (1) on each Column, leaving 4mm clearance between bolt head and nut for hanging whiteboard.



**Note:** For 50 and 60 inch whiteboard, please install the Hexagon Bolt Assemblies (1) on the first and second holes from top down on the Column. For 80, 100, 112, and 120 inch whiteboard, please install the Hexagon Bolt Sets (1) on the first and third holes from top down on the Column

Step 5. Align the Hexagon Bolt on the Column with the clip holes of Height Adjusting Bracket on backboard, and then hang the whiteboard on the stand. Finally, tighten the nuts on Hexagon Bolts.

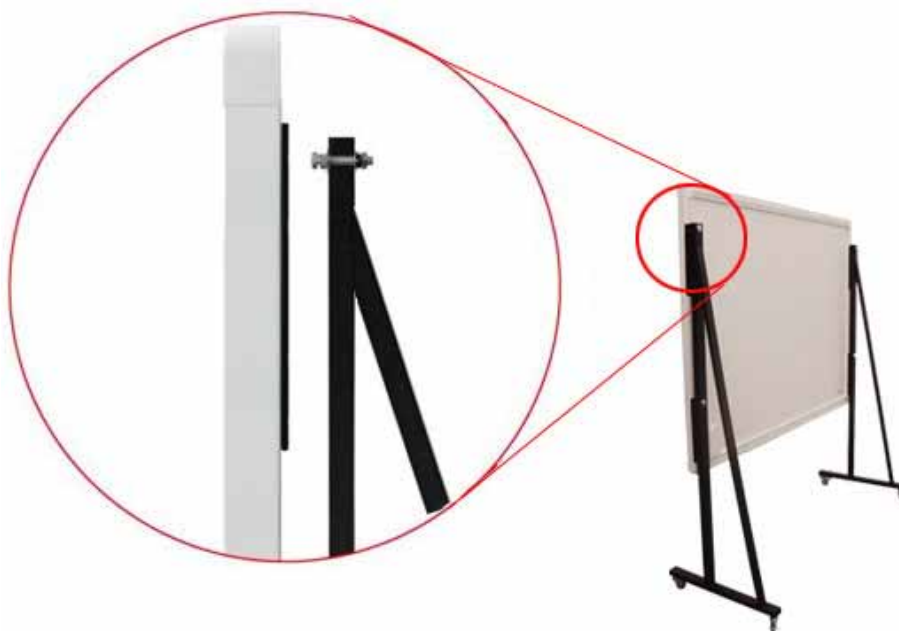



**Prompt:** You can adjust whiteboard height by using different clip holes on Height Adjusting Plate. Normally the whiteboard lower frame should be 75-80cm above ground.

## Exploded View



## 3.2 Setup electronic pen

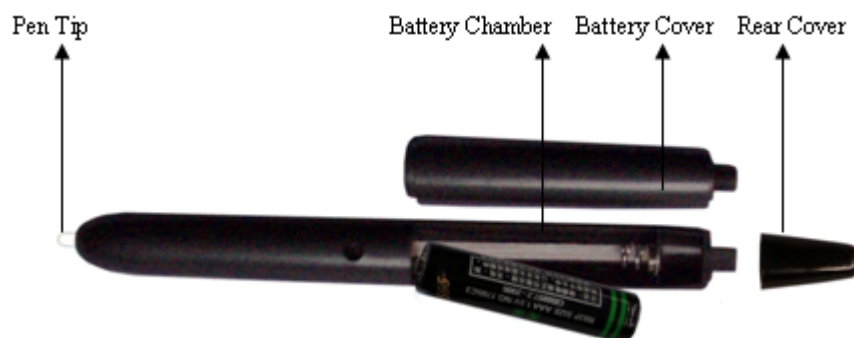

### 3.2.1 Install battery

1. Unscrew the end cap of signal pen turning it counterclockwise.



2. Remove the battery cover by pushing the cover back away from the pen tip.



3. Insert 1 AAA battery with the plus (+) side up.



4. Put the battery cover back and screw the cap back on clockwise.

### 3.2.2 Replace pen tip

The electronic pens have a removable tip, which can be replaced if it is worn out. To replace the pen tip:

1. Pull out the existing tip with your fingers or tweezers.
2. Insert the replacement tip and push into place fully.

## Chapter 4 Connecting with Computer and Projector

After fixing the whiteboard, find a connecting port on the backboard right bottom. Plug the quadrate side of USB cable into the connecting port, and plug the flat side into the available USB port of computer, as follows. External power source is not required. And please connect the Projector into the VGA port of your PC video card.

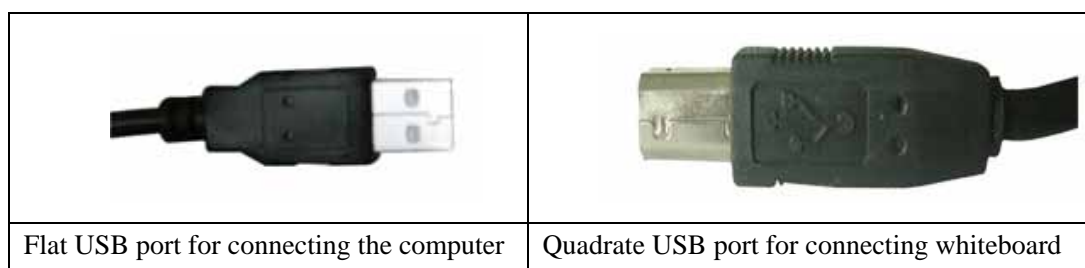

If your product model is with “B” letter (refer to “About model” for detailed explanation for product model), you also can use wireless Bluetooth for PC connection, the connecting steps are as follows:

Step 1. After fixing the whiteboard, insert the round terminal of the 5V transformer into a round jack on the backboard right bottom, and insert the power plug of the 5V transformer into a power socket.



**Note:** If your product model is with “N” letter (refer to “About model” for detailed explanation for product model), the round jack is on the right bottom of the backboard.

Step 2. Plug the Bluetooth adapter into an available USB port of computer. And please connect the Projector into the VGA port of your PC video card.



Open the projector after connection, and adjust it to make its projection within the active area and centered. Then use the trapezoid rectification function of the projector

to make the projection quadrate.



Maximum projection area for whiteboards without hotkey or with hard hotkeys



Maximum projection area for whiteboards with soft hotkeys

The blue areas are the maximum projection areas. For whiteboards without hotkey or with hard hotkeys, there should be 2cm margin between projection area and whiteboard inner frame. For whiteboards with soft hotkeys, the projection area should not exceed the hotkeys.



**Note:**



- 1. In case you use 16:9 whiteboard, please choose the projector supporting the 16:9 projection mode.*
- 2. The projection image must be within the active area of the whiteboard, otherwise the whiteboard cannot work normally.*

# Chapter 5 Install and Uninstall Drivers

## 5.1 Install Drivers

Run “IQBoard ET & PS Drivers.exe” in the installation CD, and install the drivers according to the prompt. The computer will automatically find a new hardware and install the drivers.

After the installation is completed, if the indicator beside the USB connecting port turns green, the whiteboard can be used normally. If the indicator turns red, it means the USB cable is not well connected, please re-connect the USB cable or restart computer. If the indicator is not lighting, it means the USB cable is not connected.

		
Indicator is not lighting	Indicator turns red	Indicator turns right
USB cable is not connected.	USB cable is not well connected, or the drivers are not correctly installed	The whiteboard works normally.



### **Prompt:**

1. If it is the first time you connect the computer to the whiteboard, and the drivers are not installed, the system prompt “Found New Hardware”, you can ignore or close the prompt, and continue to install the driver accord to the above steps.
2. No restriction on Windows user account (Administrator, Guest, and Limited User).

## 5.2 Uninstall Drivers

Select “Start > Programs > IQBoard ET & PS Drivers >Uninstall” to uninstall. You also can open Control Panel, select “Add/Remove Programs”, and in the list of currently installed Programs, select “IQBoard ET & PS Drivers”, then press the “Change/Remove” button to remove the drivers.

# Chapter 6 Orientation and Hotkey Setting

## 6.1 Orientation

At the first time you use the whiteboard, you need to orient it, so the moving track of the electronic pen or writing pen (finger) can match the cursor. You can select 4 points, 9 points or 20 points orientation. Normally 9 points orientation is adopted. After the whiteboard is oriented, you don't need to re-orient at the same environment.

Operation steps are as follows:

Step 1. Select “*Start > Programs > IQBoard ET & PS Drivers >Orient*” to enter the Orient Precision Selection window, as follows. If your product model is without H, N and T, you also can press “” in the hotkey bar.

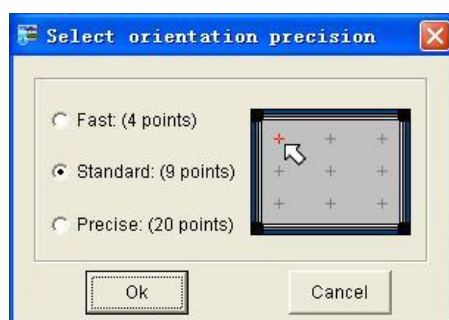

Step 2. Select Orientation Points and click “*Ok*”, the orientation interface will appear. According to the arrows instruction, use electronic pen or writing pen (finger) to press the green center of the flickering red “+” on the surface. If the cursor is on the same point, this point is successfully oriented. And the next point appears. The whole orientation process is simply using your signal pen to click each orientation point in sequence.

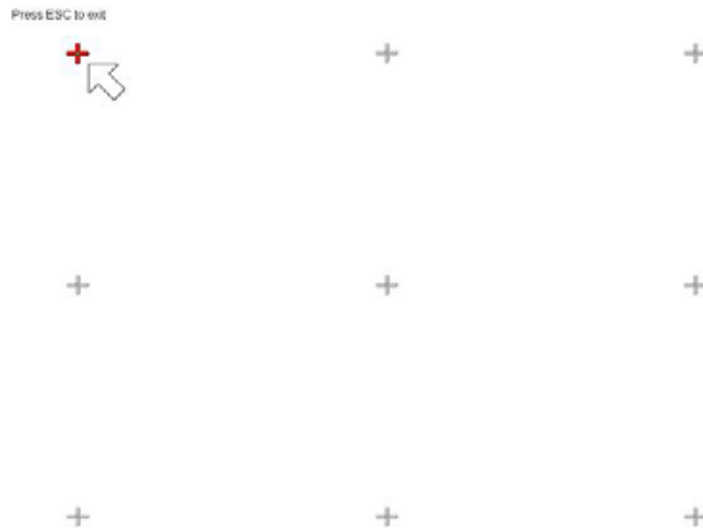

Step 3. The Orientation Interface will close automatically after finish the orientation. Then you can use electronic pen or writing pen (finger) to operate on the whiteboard normally.



**Prompt:**

- 1. If you did not locate the accurate central point or clicked the wrong point, or the next fixed point appeared without press, please press "ESC" on the keyboard to exit this orientation and re-orient. Otherwise you can't operate the whiteboard accurately.*
- 2. Please make your electronic pen or writing pen (finger) upright when orienting.*
- 3. In case the relative position of the whiteboard and projector is changed, or the driver or the monitor resolution is altered, please re-orient.*

## 6.2 Hotkey Setting

At the first time you use the whiteboard with soft hotkeys, you need to set these hotkeys.

Step 1. Select "Start > Programs > IQBoard ET & PS Drivers > Hotkey setting" to enter the setting window, as follows



Step 2. Follow the indication on screen, click relevant hotkey in sequence. After the setting is completed, you can use these hotkeys.

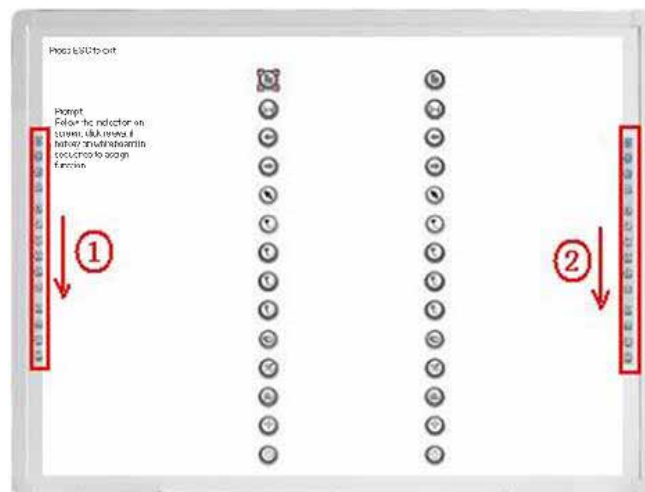

**Prompt:**

1. When setting the soft hotkeys, if some error occurs, you can press “ESC” key on the keyboard to exit the setting process, and then reset the hotkeys.
2. You don't need to set the hard hotkeys.

# Chapter 7 Operation

## 7.1 Skills of pressing and writing

**Single-click & Double-click:** Do not raise the electronic pen or writing pen (finger) too much (about 1-2mm from the tip to the surface), keep the angle between pen and surface more than 50°, then press the surface at proper strength. The operation of double-click on board has the same definition as double-click mouse in Windows, please make sure you click at the same point.

**Drag:** Use the electronic pen or writing pen (finger) to press an item and drag it to the appointed position (during which the pen tip or finger tip should not leave the surface)

**Write:** If you use IQBoard Software, you can use the drawing tools to directly write on the surface. (The writing strength should be the same as using the normal whiteboard pen.)

**Orient:** If the pressing position does not match the cursor, please re-orient. If the deviation still exists, please check the installation of the whiteboard.

**Right-click:** Click the surface and hold for 2 seconds to popup the right-key menu. (IQBoard Software also provides this function. Refer to IQBoard Software User Manual for details).



**Note:**

- 1. Please use the 1024\*768 resolution. Close all energy saving modes to avoid performance delay caused by dormancy.*
- 2. To lengthen life span of the battery, please take it out if you will not use the electronic pen for a long time.*

## 7.2 Hotkeys

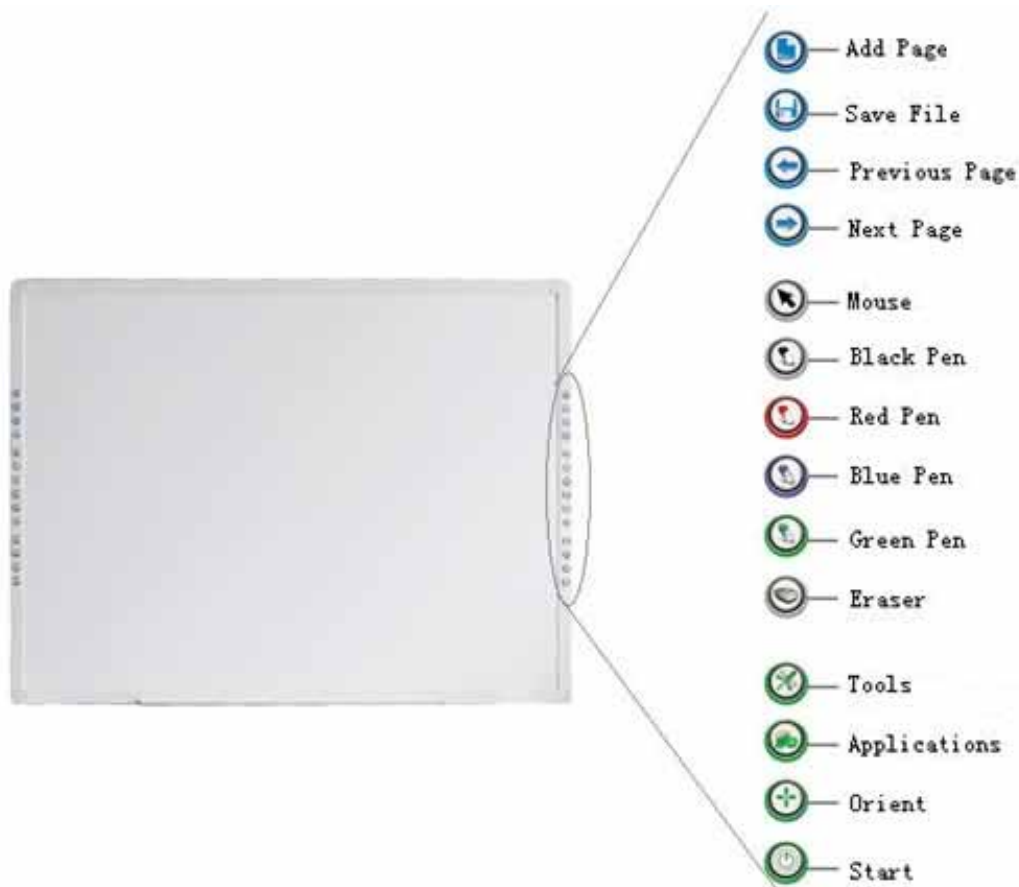



Following is the introduction of these hotkeys.

**Add Page** : In Windows Mode, press this key to clear all annotations on screen. In Board Mode, Press this key to add a new page in current “cdf” file.

**Save File** : In Windows Mode, press this key to save all annotations on screen to a page in current file. In Board Mode, press this key to save the current “cdf” file.



**Previous Page** : Press this key to go to the previous page.



**Next Page** : Press  key to go to the next page.



**Mouse** : Press  key, you can use electronic pen or writing pen (finger) to achieve click, double-click, and drag function. When using IQBoard Software, press this key to switch between “Windows” and “Board” mode.



**Pen:** There are four “Pen” keys in different colors on the hotkey bar. Press one of



these keys, you can write on board in corresponding color. Press “Pen” twice to modify its properties.

**Eraser** : Press  key, you can erase the writing content on board. In “Windows” mode, press this key twice to popup the “Shut Down Windows” window.

**Tools** : Press  key to popup a quick access bar including shortcut icons for frequently used tools in IQBoard Software. You can add up to 8 shortcut icons in this bar.

**Applications** : Press  key to popup a quick access bar including shortcut icons for frequently used applications. You can add up to 8 shortcut icons in this bar.

**Start** : Press  key to start the IQBoard Software.

**Orient** : Press  key to popup the orientation interface.



**Prompt:**

1. Except the “Start” and “Orient” keys, all hotkeys are functional only after IQBoard Software is started.
2. The functions of “Frequently Used Tools”, “Frequently Used Applications”, “Orient” can be opened or closed by press the relevant hotkeys on the hotkey bar.

# Chapter 8 FAQ

## **1. The whiteboard indicator is not lighting or turns red. The hotkey is not functioning.**

1. The USB cable is not well connected with whiteboard or computer, please check and re-connect.

2. The USB port is damaged, please try another one. In case you are using desktop computer, please use its rear USB port.

3. If you use wireless connection, please make sure you have inserted the round terminal of the 5V transformer into a round jack on the right side of pen tray, inserted the power plug of the 5V transformer into a power socket, and well connected the Bluetooth adapter and computer with USB cable.

4. IQBoard ET & PS Drivers haven't been correctly installed. Please uninstall the driver, restart computer, and re-install the driver. After the installation is completed, please reconnect the USB cable with computer.

5. IQBoard Software hasn't been started, please start IQBoard Software first.

6. The driver version doesn't match. Please uninstall the driver, restart computer, and re-install the driver. You can download the universal driver of IQBoard ET & PS Drivers (for V4.5/V5.0/V6.0) on our website. After the installation is completed, please reconnect the USB cable with computer.

## **2. What kind of orientation precision should I select?**

It depends on your requirement of orientation time and accuracy. You have the following choices:

Quick orientation (4 points): for fast orientation

Standard orientation (9 points): for most of situations

Precise orientation (20 points): for high-definition system

## **3. When I touch the surface of IQBoard PS with pen or finger, the cursor doesn't move, and when I move the mouse, the cursor return to one location.**

You can try the following solutions: 1. Clear the dirt on the contact area. 2. Rub around

the contact area forcibly with fighter tip. 3. Attach a piece of tape or a small suction cup on the contact area, then gently pull the front layer away from the back layer. If the problem still exists, please contact our service center.

**Background knowledge:** The surface of IQBoard PS is made of two separated layers. In normal circumstance, these two layers will be temporarily contacted when you touch the screen with pen or finger, and will be separated again when you lift the pen or finger. But if continuous force is exerted on one area, the front layer and back layer may stuck together, leave a constant sensing point.

**4. When operating and writing on the whiteboard, the position of pen or finger doesn't match the position of cursor.**

1. The relevant location of projector and white has been changed. Please re-orient the whiteboard.
2. The projection area has trapezoid distortion, please adjust the projection area, and re-orient the whiteboard.
3. When orienting the whiteboard, the pen or finger is not perpendicular to the surface, please re-orient with correct posture.
4. When orienting the whiteboard, the pen tip or finger tip missed the green center of the red orienting cross, please re-orient the whiteboard.

**5. When operating and writing on the whiteboard, the system respond is slow, or the stroke is Intermittent.**

The computer is not under normal running or the memory is occupied too much. Please close some applications or restart the computer.

The operating or writing force is uneven. Sometimes the force is too light to be sensed.

**6. When I operate and write on the IQBoard ET with electronic pen, the system doesn't respond.**

1. The electronic pen runs out of battery, please replace the battery.
2. The body of electronic pen is loose, please tighten it.
3. Please check whether the whiteboard indicator is green, if not, please refer to the solution of Question 1.

## **7. When using IQBoard ET, the cursor is out of gear or the whiteboard can't be oriented.**

There is interference source nearby, such as high voltage cable or large generator set which can generate strong magnetic field.

**Background knowledge:** IQBoard ET adopts working principle of electromagnetic induction. So if there is interference source that can generate strong magnetic field nearby, the above symptom will occur. In normal condition, devices like cell phone, display, TV won't affect IQBoard ET. In case the interfering magnetic field is too strong, you can move either the interference source or IQBoard ET to keep their distance over 50cm.

## **8. The pen tip worn out.**

Common abrasion will not affect normal operation. When the pen point is severely abraded, you can purchase it from local dealer.

Other questions, please consult our service center or local dealer.

# Chapter 9 Cautions and Maintenance

## 9.1 Whiteboard

For the interactive whiteboard that do not support normal marker (the product model is without “W”), please try not to use normal marker to write on the surface. Before cleaning, please shut down the computer and switch the projector into standby mode to make the dirt more obvious. In case of normal dirt, spray some water or detergent on the surface, then use the paper to wipe the dirt out. If you leave some ink trail by mistakenly using the fountain pen, please buy some special whiteboard detergent and spray it on the soft cloth to clean to surface. For cleaning the mark left by the permanent marker, first paint some ink of dry erase marker on the mark (the ink of dry erase marker can dissolve the ink of permanent marker), then use soft cloth to clean. If the mark still exists, spray some whiteboard detergent, and clean it out.



**Note:** Please do not use other organic solvent for cleaning. Otherwise it may permanently damage the surface.

2. For the interactive whiteboard that support normal marker, you can use normal whiteboard eraser and wet cloth to clean.



**Prompt:** Clean the frequently used whiteboard once a week to keep the best definition.

3. Please do not use sharp or pointed objects to scratch the surface and frame, otherwise the scratched part may be damaged, and won't work normally. During the usage, do not knock the surface fiercely to avoid the damage of whiteboard surface and electronic pen (writing pen). You can use sand wax to eliminate the scratch on the surface, and use dry cloth to clean out.

4. Since the mobile stand (or the wall hanging parts) is designed only to support the weight of the whiteboard, please do not put the additional weight or pressure on the whiteboard. Please keep the whiteboard away from intense collision, shaking, pressing and do not install it by force, otherwise it may cause cracking, short circuit and surface distortion.

5. Please do not use and install interactive whiteboard in dusty, foggy, wet and inclement environment. Keep it away from sharp object, heat source, corrosive chemicals, fire, and water. Please do not put the whiteboard in the outlet of hot air, otherwise the material will deteriorate and its life-span will be shortened.

6. To avoid harm from improper operation, please do not use chair or other tool to help short students use the whiteboard. If students can not use whiteboard because of the limitation of their height, please low down the whiteboard under the help of professional technician.

## 9.2 USB Cable

Do not put the USB cables on the floor where it may stumble others. If you have to do so, straighten them and use insulated adhesive tape or cable with contrast color to tie them up. Please handle carefully and avoid over-bending. Exposing the USB cable outside for a long time may shorten its life-span and cause other unnecessary damages, so please keep it carefully. If you use the whiteboard in the meeting room or class room, please fix the cable according to the cable alley.



**Note:** *Since the USB cable and port are made in special specification, please do not use other USB cable and port for replacement.*

## 9.3 Projection

Face the whiteboard when operating and writing on the projected image, stand aside when you turn back to face the students. Please do not look at the projector directly to avoid its strong light damaging your eyesight. Instruct students how to use the whiteboard, tell them do not to face the projector directly.

## 9.4 Transport

Please handle with care, and do not put any weight on the surface so as to avoid the surface distortion and damage. Lay the whiteboard upright during the transportation or storage. In long distant transportation, it is suggested to repack the whiteboard with the original packing. If the original packing is unavailable, insert some protective padding between the components to protect them from intense vibration or crash. Avoid vibration, dampness, electricity, water and pressure in transportation.

## 9.5 Part Replacement

Please do not disassemble the whiteboard or modify its inner structure so as to prevent accident or trouble. For maintenance or part replacement, please resort to our authorized technician. Make sure that you use our designated part or the one with same specification when replacing.